

The Lawn Cemetery



Rushmere St Andrew Parish Council



Rushmere St Andrew Parish Council

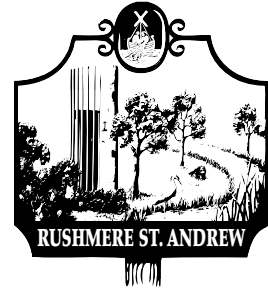

Registrar to The Burial Authority

Mr Andrew Duncan
8 Crofton Close
Ipswich, Suffolk IP4 4QR
Tel 01473 727389

Parish Clerk

Mrs Sylvia Stannard
Tel 01473 711509
email sylvia.stannard@rushmere-st-andrew.org.uk

Assistant Clerk

Mrs Sarah Jenkins
Tel 07548 177667
email sarah.jenkins@rushmere-st-andrew.org.uk

Postal Address

Parish Office, Tower Hall
5 Broadlands Way
Rushmere St Andrew, Ipswich IP4 5SU
Parish Office contact number 01473 711509

Published by Rushmere St Andrew Parish Council
First edition September 2010
Second edition September 2015
Revised December 2017

Rushmere St Andrew Lawn Cemetery

REGULATIONS

(revised December 2017)

Made by Rushmere St Andrew Parish Council acting as The Burial Authority

GLOSSARY

GRAVE SPACE means a burial place formed in the ground by excavation and without any internal wall of brickwork or stonework or any other artificial lining. See Figure 1 for grave space dimensions.

URN BURIAL PLOT means a burial place formed in the ground by excavation and without any internal wall of brickwork or stonework or any other artificial lining. See Figure 2 for urn burial plot dimensions.

THE BURIAL AUTHORITY (The Authority) means the members of the Rushmere St Andrew Parish Council for the time being.

REGISTRAR TO THE BURIAL AUTHORITY (The Registrar) means the person appointed by Rushmere St Andrew Parish Council for the time being.

NATIONAL ASSOCIATION OF MEMORIAL MASONS (NAMM)

BRITISH REGISTER OF ACCREDITED MEMORIAL MASONS (BRAMM)

GRAVE SPACE AND URN BURIAL PLOT

- 1 The selection of the site for any grave space or urn burial plot shall be at the sole discretion of The Authority.
No specific plot can be reserved.
- 2 Exclusive Right of Burial in a grave space or urn burial plot may be purchased for a period of 100 years after which all rights return to The Authority, unless the rights are renewed.
- 3 Residents fees: A resident is a person who is or was an inhabitant of the civil parish of Rushmere St Andrew.
- 4 When an additional interment is required in a burial place, the current holder of that Exclusive Right of Burial place must give consent in writing delivered to the Registrar along with the notice of interment.
- 5 In purchased grave spaces a minimum layer of earth 150mm in thickness must be left between each coffin interred there and 900mm of earth at least between the top of the upper coffin and the ordinary level of the ground.
- 6 For persons of 12 years and upwards no grave shall be less than 1.7m in depth or for those under the age of 12 years less than 1.2m in depth from the surface of the ground.
- 7 After settlement no grave in the lawn cemetery shall be raised by turfing or in any other manner above the level of the ground immediately adjoining.
- 8 As soon as convenient after interment of a body in The Lawn Cemetery, The Authority will sow seed or turf over the whole area of the grave with the exception of a headstone area of a grave space, see Figure 1.
- 9 As soon as convenient after the burial of an urn containing ashes in an urn burial plot in The Lawn Cemetery, The Authority will sow seed or turf over the whole area except for an area required for a flat stone or plaque, see Figure 2.
- 10 The Authority will maintain the whole of the turfed area of the lawn cemetery.
- 11 In order to facilitate maintenance of The Lawn Cemetery, no trees, shrubs, plants, wreaths, glassware or platter jars, vases or any other thing whatsoever will be permitted on the turfed area.
- 12 Dead or unsightly vegetation must be removed.

MEMORIALS, VASES, MEMORABILIA AND VEGETATION

- 13** No grave space or urn burial plot shall have a headstone erected upon it unless the Exclusive Right of Burial in that space has been purchased.
- 14** No structures to enclose or cover grave spaces, other than headstones, wooden crosses and vases referred to in Regulations 15 and 18, will be permitted to be erected on or around graves in The Lawn Cemetery, with the exception of flat stones or plaques on urn burial plots referred to in Regulation 16.
- 15** Grave space headstones and crosses in the lawn cemetery shall be erected vertically 75mm from the outer edge of the headstone area at the head of the grave space in line with the headstones of adjoining graves and in positions approved by The Authority. Headstones shall not exceed the overall dimensions shown in Figure 3.
- Headstones shall be of materials as described in regulation 17.
- A permanent wooden cross may be erected in place of a headstone and shall be constructed not less than 90mm in width and 50mm in thickness and not more than 150mm in width and 75mm in thickness, and when erected shall not exceed the overall dimensions shown in Figure 3, such erection to be to the satisfaction of The Authority.
- 16** Urn burial headstones, permanent wooden crosses and flat stones or plaques shall be placed 75mm from the outer edge of the plot in line with adjoining urn burial memorials and in a position approved by The Authority.
- Headstones shall not exceed the overall dimensions shown in Figure 4 and of materials as described in regulation 17. Permanent wood crosses may be erected and shall not exceed the overall dimensions shown in Figure 4.
- Flat stones or plaques shall not exceed an area of 450mm by 450mm.
- 17** Memorials shall be of natural stone and black, grey or white in colour only.
- Each memorial shall have a foundation and be fixed with stainless steel anchor/s and anchor markings to comply with current (NAMM and BRAMM) regulations to BS8415.
- Book Style memorials must be anchored on all parts. Permanent wooden crosses shall be of a suitable hardwood.
- 18** No advertisement or trademark shall be inscribed on the headstone.
- On the back of the headstone close to the base of each memorial the mason's name and the number of the grave and anchor symbol shall be clearly cut and painted in letters and numerals not exceeding 25mm in height.
- 19** Integral vases of stone must be set in or on the plinth immediately in front of the headstone.
- 20** Temporary marker crosses may be placed on the grave space at the time of interment but must be removed upon the erection of any permanent memorial/headstone.
- The Authority will dispose of any temporary marker cross remaining after a short period.
- 21** All headstones, permanent wooden crosses and inscriptions are to be subject to the approval of The Authority and a copy of every proposed inscription and a drawing showing the form and dimensions must be left with the Registrar for approval.
- Any memorial removed for an additional inscription must be replaced to the specifications contained within these regulations with particular reference to regulations 17 and 18.
- 22** The Authority will undertake periodic safety inspections and carry out minor remedial work to headstones.
- The Authority will make every effort to contact owners of headstones if major repairs are considered necessary, but reserves the right to remove or lay down any headstone which it deems to be unsafe.
- 23** Notwithstanding regulation 22, The Authority will not be held responsible for the safety of, or any

damage to headstones. Insurance is available from stonemasons and funeral directors.

- 24 Freestanding vases, glassware, jam jars, milk bottles or similar jars or other potentially injurious articles will not be allowed upon headstones, grave spaces, urn burial plots or anywhere else within The Lawn Cemetery.
- 25 Wind chimes, solar lights, audio equipment or any other ornamentation as The Authority determines from time to time will not be allowed upon turfed grave spaces or headstone plinths or anywhere else within The Lawn Cemetery.
No trees, shrubs, plants, flowers may be grown or placed on turfed areas or anywhere else in The Lawn Cemetery.
- 26 Photographic, computer generated or similar images are not permitted in The Lawn Cemetery.
- 27 **The Authority reserves the right to remove any vegetation, object, item, or memorabilia from The Lawn Cemetery.**
- 28 The Authority's decision in relation to any breach of the Regulations shall be deemed final.

INTERMENT NOTICE AND FEES

- 29 Notice of any interment is to be given to the Registrar during reasonable hours and no application can be received nor any interment take place on Sundays except at the discretion of The Authority.
- 30 The notice of interment must contain a statement of the full name, age and occupation of the deceased, the date of death and parish in which the death occurred, the date and time of the intended burial, the location and description of the grave, and by whom the grave has been purchased.
The notice of burial must give the accurate and exact outside dimensions of the coffin to be used for burial, inclusive of handles and other ornamentation.
Present standard coffin sizes for graves are 308cm long x 75cm wide.
Proposals to use a coffin exceeding these sizes must be referred to the Registrar for individual advice.
- 31 No burial may take place before 09.00 hours in the morning or after sunset without the special permission of The Authority.
- 32 All fees and charges according to the current Schedule of Fees and Charges are to be paid to the Clerk of the Parish Council. If fees and charges are not paid in full prior to burial, the Authority allows a period of 30 days for fee payment after the burial, after which time interest of 5% may be payable on any outstanding amount.

GENERAL

- 33 A register of burials will be kept by the Registrar and searches may be made of the register and certified extracts obtained for a fee, at all reasonable times at the discretion of The Authority.
- 34 Visitors to The Lawn Cemetery shall not, except for the purpose of properly attending any grave that they are authorised to tend, remove flowers or wreaths placed on any other grave.
- 35 Persons shall not distribute any business card, advertisement or literature of any kind within The Lawn Cemetery.
- 36 Persons shall not sell or offer to sell or display for sale in The Lawn Cemetery any article, commodity or anything of any kind whatsoever.
- 37 Dogs are not allowed in The Lawn Cemetery unless kept on a short lead.
- 38 Unauthorised vehicles are not allowed in The Lawn Cemetery.
- 39 The Authority will take all reasonable precautions to ensure the safety of persons visiting The Lawn Cemetery, but all persons entering the Cemetery do so at their own risk.

GRANT OF EXCLUSIVE RIGHT OF BURIAL

This can be complicated and difficult to understand. The Regulations below are supplemented by an explanation of what the Regulation wording implies depending on circumstances. If you need more information or assistance after reading this information please contact any of the persons listed in the 'Schedule of Fees and Charges' section of the Regulations or talk to your funeral director, stonemason or solicitor.

40 The Authority may grant, subject to the payment of the appropriate fee, the Exclusive Right of Burial in respect of private graves (this applies to both grave spaces and urn burial plots).

- If you purchase an Exclusive Right of Burial we will issue you with a **Deed of Grant** the details of which will be recorded in a register held by the Registrar.
- For the Rushmere St Andrew Lawn Cemetery the granting of Exclusive Right of Burial also includes the right to erect a memorial (see Regulation 43)
- If the Exclusive Right of Burial is not purchased then only a small wooden cross can be erected on the grave space or urn burial plot.
- If families choose not to purchase the Exclusive Right of Burial the deceased will be buried in an unpurchased grave (public grave) and other unrelated people may have been buried in this grave previously or will be in the future.
- UK law says that the Exclusive Right of Burial for a grave cannot be purchased for more than 100 years. However, on payment of a fee, there is a facility to 'top-up' the lease every ten years. In this manner, a grave can stay in the family for as long as they wish, though the Right will never be issued for more than 100 years at any one time. You (or your family) can also renew the Right at the end of the current lease. It is very important that you inform The Authority if you change address, otherwise you may not receive a notice of renewal at the appropriate time.
- You can transfer or assign ownership of a Deed of Grant by completing an 'Assignment of an Exclusive Right of Burial' form. This form is available from Solicitors, the Registrar, Clerk or Assistant Clerk and may be available from some funeral directors.
- If or when a grave owner dies, the Deed of Grant of Exclusive Right of Burial document is considered to be part of the Estate of the deceased.
- A transfer of ownership can legally take place on the production of a Grant of Probate or Letters of Administration. If one or the other of these legal documents has not been issued a Statutory Declaration made by the lawful next of kin must be completed.
- It is advisable that any transfer of the Grant is registered with The Authority for which a small registration fee is payable.

41 The ownership of the ground does not, **at any time**, pass from the control of The Authority.

If you purchase the Exclusive Right of Burial for a grave space or urn burial plot it does not mean you own the actual land. However, the owner named in the Deed of Grant has the right to:

- be buried in the grave if space is available
- authorize further burials in the grave, where space is available
- authorize the interment or scattering of cremated remains in the grave
- place an inscribed memorial on the grave.

42 Before the reopening of a purchased grave space or urn burial plot (for a second or third interment or burial of ashes), the ownership of the Exclusive Right of Burial for that grave space or urn burial plot must be proven.

- Where the interment or burial of ashes is not of the registered owner of the Right, the written consent to the opening of the grave must be obtained from the owner of the Right. (*A form for this should be provided by the funeral director and is also available from The Authority.*) The only exception to this is where the burial is to be that of the registered owner in which case no written authority is required.

- If you own the Exclusive Right of Burial for a grave no one else can be buried in it if you don't want them to and UK law protects your rights as registered owner of the grave.
- 43** By proper application, and payment of the appropriate fee (*usually via the stonemason*), the right to erect a memorial will be granted to the Rightful Owner of the plot.
- The Rightful Owner is the person named in the Exclusive Right of Burial when section 42 will apply as above.
 - Prior to a memorial being erected on a grave space or urn burial plot, the written authority of the Rightful Owner of the grave must be included with the application to erect the memorial.
 - The right to erect a memorial is deemed to be granted on acceptance by the Authority of the application to erect a memorial and payment of the appropriate fee. There will be no dedicated Deed of Grant for Memorials issued by The Authority.
- 44** Irrespective of the Exclusive Right of Burial being granted in a grave space or urn burial plot, or the number of burials for which the Grant was obtained, no grave will be excavated or body buried therein, which would contravene Part 1 of the Second Schedule to the Local Authorities Cemeteries Order 1977.
- Part 1 of the Second Schedule is the Statute which lays down certain regulations regarding the Exercise of Rights in relation to the management of the grave space by The Authority (*A copy of the 1977 Order is available from the Clerk or Assistant Clerk*).

LOOSE BURIAL OF CREMATED REMAINS

- 45** Placement of loose ashes in a pre-designated area (common plot) within the Lawn Cemetery for which no exclusive rights of burial are required and no memorial headstone is permitted. NOTE: Formal registration in the Register of Burials is, however, required and ashes cannot be placed or scattered on the surface of the ground (under the turf is the normal method). Reservation of spaces in this area will not be permitted.

BRAMM ACCREDITATION

- 46** Only BRAMM (British Register of Accredited Memorial Masons) accredited memorial masons will be allowed to carry out memorial works within Rushmere St Andrew Lawn Cemetery.

ADOPTION OF REGULATIONS

The above Regulations were adopted under delegated powers at a meeting of the Rushmere St Andrew Parish Council General Purposes and Finance Committee, for the Rushmere St Andrew Burial Authority (The Authority), on 14 December 2017.

These Regulations supersede any previous versions of the Regulations.

P M Richings	Chairman
J Wright	Vice-Chairman
S Stannard	Clerk to the Parish Council

SCHEDULE OF FEES AND CHARGES

A copy of these regulations and the current schedule of fees and charges can be obtained from:

The Clerk to Rushmere St Andrew Parish Council

Mrs Sylvia Stannard, email sylvia.stannard@rushmere-st-andrew.org.uk

The Assistant Clerk to the Parish Council

Mrs Sarah Jenkins, email sarah.jenkins@rushmere-st-andrew.org.uk

Parish Office, Tower Hall, 5 Broadlands Way, Rushmere St Andrew, Ipswich IP4 5SU
Tel 01473 711509

Registrar to the Burial Authority

Mr Andrew Duncan, 8 Crofton Close, Ipswich, Suffolk IP4 4QR Tel 01473 727389

A copy of the schedule of fees and charges can be downloaded [by clicking here](#)

Figure 1

GRAVE SPACE DIMENSIONS

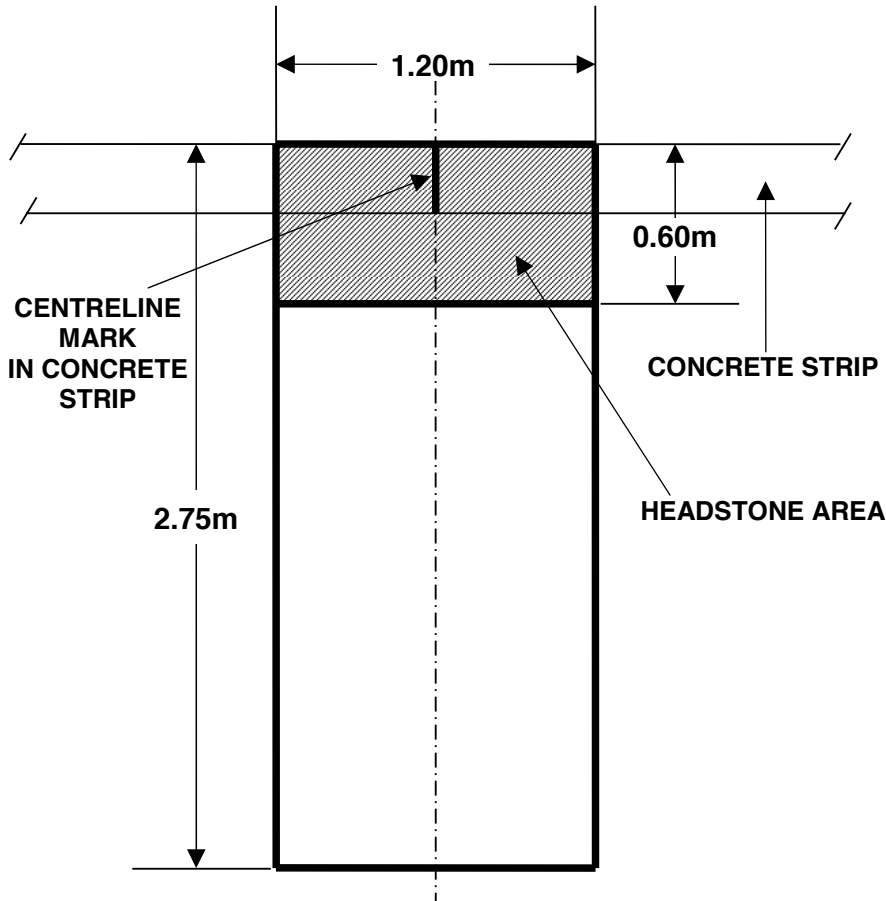

Figure 2

URN BURIAL PLOT DIMENSIONS

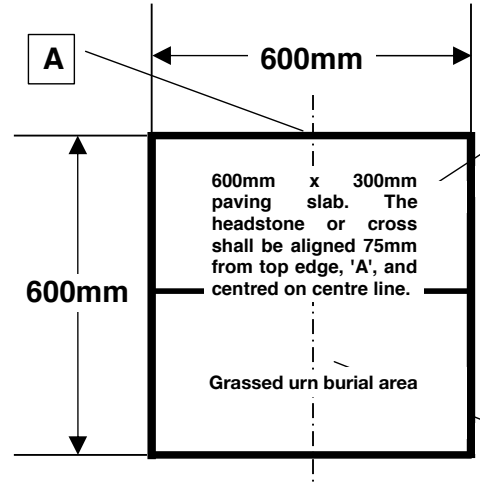

Figure 3

GRAVE SPACE HEADSTONE and CROSS OVERALL DIMENSIONS

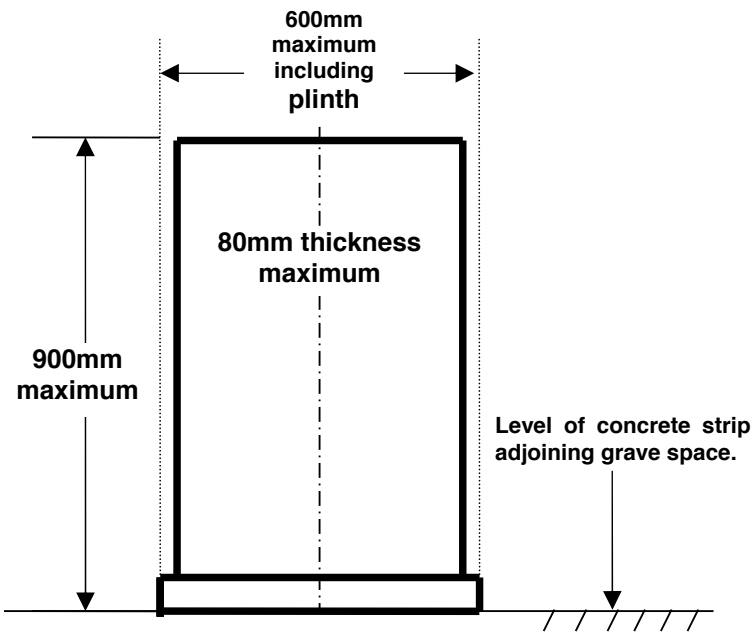
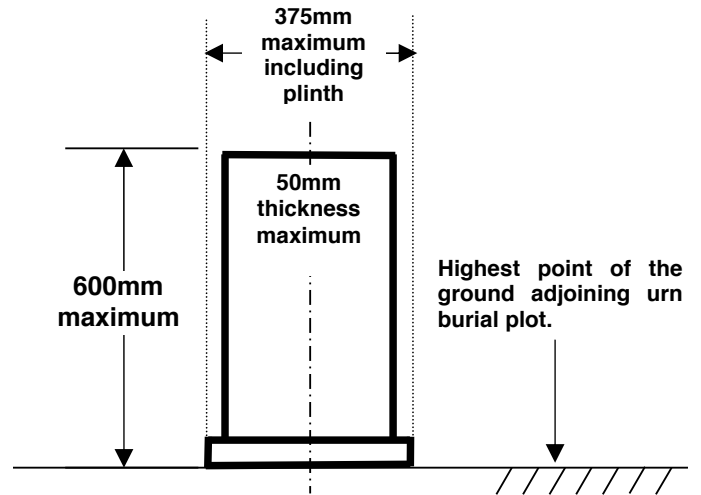

Figure 4

URN BURIAL PLOT HEADSTONE AND CROSS OVERALL DIMENSIONS



Note: The dimension of a flat stone or plaque shall not exceed 450mm by 450mm.

For fixing of memorial headstones please see regulation 17

Copies of these regulations can be obtained from

Mrs S Stannard

Tel 01473 274859 email sylvia.stannard@rushmere-st-andrew.org.uk